

ASEPTIC S PRIS

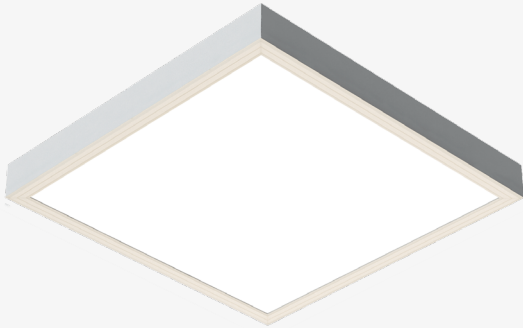

Instruções de montagem  
Mounting instructions  
Instructions de montage

1 OFF

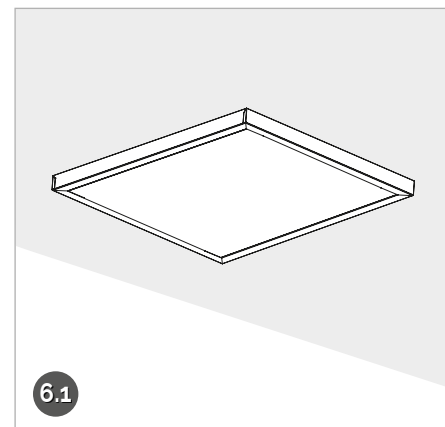
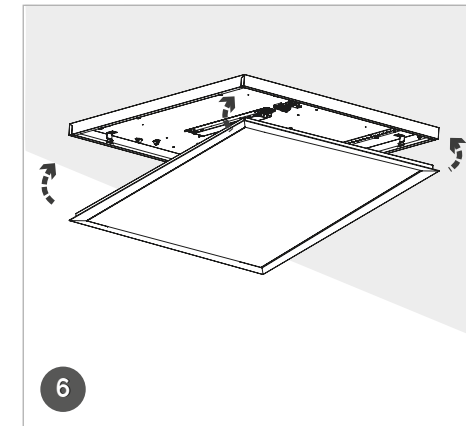
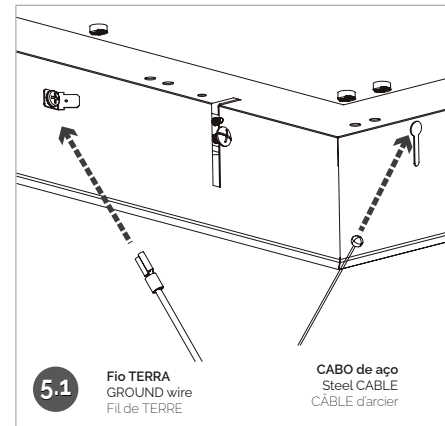
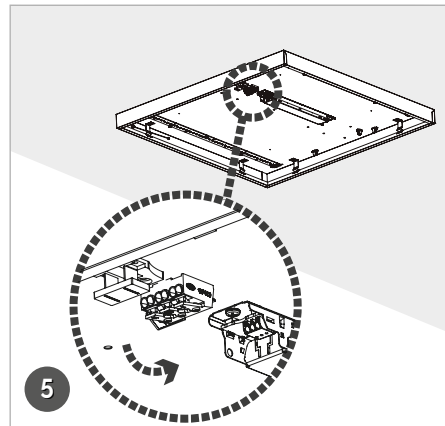
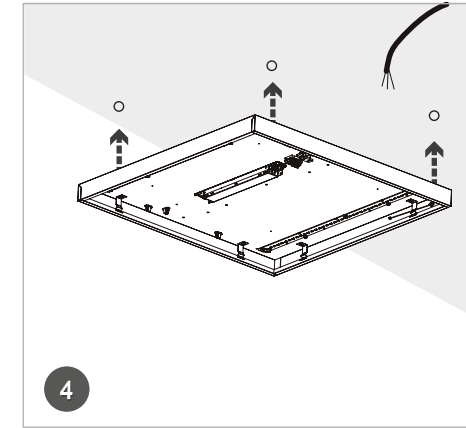
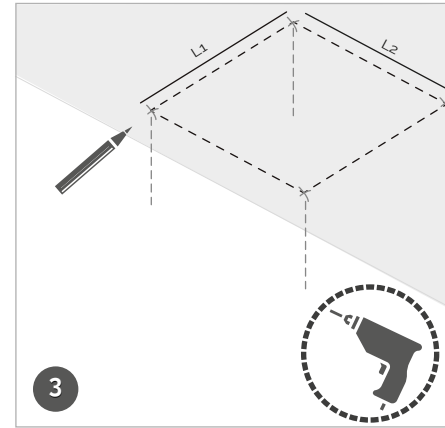
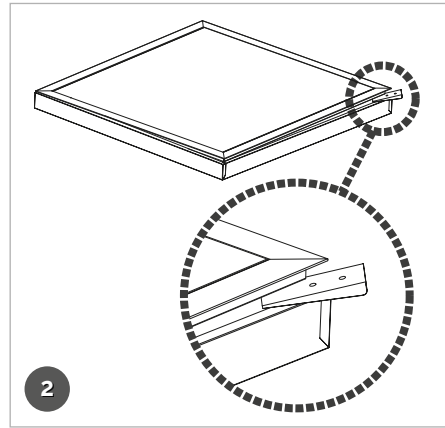
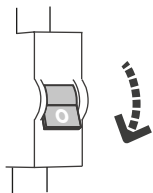

- 1** ⚠ **Desligar o disjuntor correspondente à linha em intervenção;**  
Turn off the circuit breaker corresponding to the intervention line  
Désactivez le disjoncteur correspondant à l'intervention en ligne
- 2** **Retirar a frente da luminária com uma cunha;**  
Remove the front of the luminaire with a wedge;  
Retirer la face avant du luminaire à l'aide d'une cale ;
- 3** **Realizar as marcações, e abrir furo no teto;**  
CONSULTAR TABELA 1  
Make the markings and drill a hole in the ceiling;  
SEE TABLE 1  
Faites les marques et percez un trou dans le plafond ;  
VOIR TABLE 1
- 4** **Fixar a luminária ao teto;**  
Fix the luminaire to the ceiling;  
Fixer le luminaire au plafond ;
- 5** ⚠ **Eletrificar a luminária;**  
LIGAR O CABO DE REDE  
CONSULTAR ESQUEMA 1  
Electrify the luminaire;  
CONNECT THE NETWORK CABLE  
SEE SCHEME 1  
Electrifier le luminaire ;  
CONNECTER LE CÂBLE RESEAU  
VOIR DIAGRAMME 1
- 6** ⚠ **Aplicar o corpo do difusor, encaixando os cabos de aço e o fio terra na patilha;**  
APLICAR A FRENTE DO CORPO  
Apply the diffuser body, fitting the steel cables and ground wire to the tab;  
APPLY TO THE FRONT OF THE BODY  
Appliquer le corps du diffuseur, en installant les câbles d'acier et le fil de terre sur la languette  
APPLIQUER À L'AVANT DU CORPS
- 7** ⚠ **Ligar o disjuntor correspondente à linha em intervenção**  
Turn on the circuit breaker corresponding to the intervention line  
Connectez le circuit correspondant disjoncteur à l'intervention de ligne

Nota  
Note  
Remarque

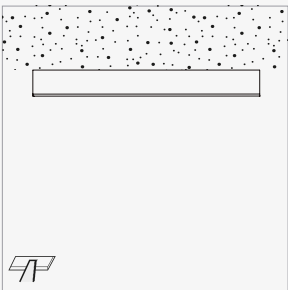

Furo de teto: TABELA 1  
Ceiling hole: TABLE 1  
Trou au plafond : TABLEAU 1

Este produto contém uma fonte de luz da classe energética A  
This product contains an energy class A light source  
Ce produit contient une source lumineuse de classe énergétique A

Tabela 1 | Table 1 | Tableau 1

MODELO	L1 (mm)	L2 (mm)	L3 (mm)
600x600	597	597	65
300x1200	297	1197	65
300x1500	297	1497	65

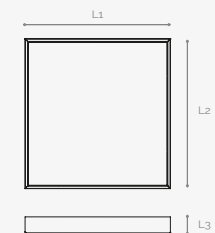

Esquema 1 | Scheme 1 | Schéma 1

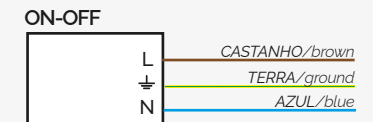
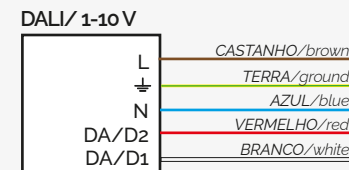

**IMPORTANTE:** Para mais informação sobre as diferentes arquiteturas, soluções e funcionalidades disponíveis, por favor contactar a Lightenjin.

São Rejeitadas todas as responsabilidades por defeito ou danos provocados por montagem incorrecta da luminária, incorrecta alimentação e agentes externos.

**IMPORTANT.** For more Information about different architectures, solutions and available functionalities, please contact Lightenjin

Are Rejected all liability for defects or damage caused by incorrect installation of the luminaire, Misfeeding and external agents.

**IMPORTANT.** Pour plus d'informations sur les différentes architectures de réseau, solutions et fonctionnalités disponibles, contactez Lightenjin.

Sont rejetées toute responsabilité pour les défauts ou les dommages causés par une mauvaise installation du luminaire, Mauvaise alimentation et les agents extérieures.

