

FERRUM S

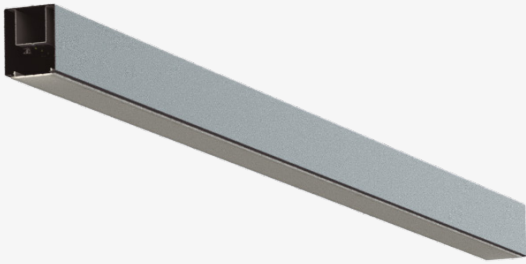

Instruções de montagem
Mounting instructions
Instructions de montage

1 OFF

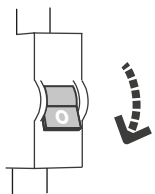

LIGHTENJIN II - Indústria de Iluminação, Lda
Parque Empresarial do Casarão, Avenida das 2 Rodas,
Lote 36A. 3750-041 Aguada de Cima | Portugal
tel: +351 234 080 117 | fax: +351 234 640 064
geral@lightenjin.pt | www.lightenjin.pt

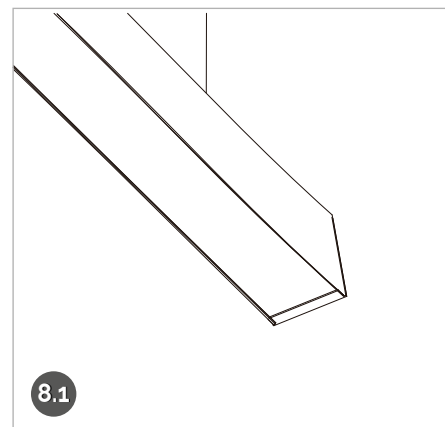
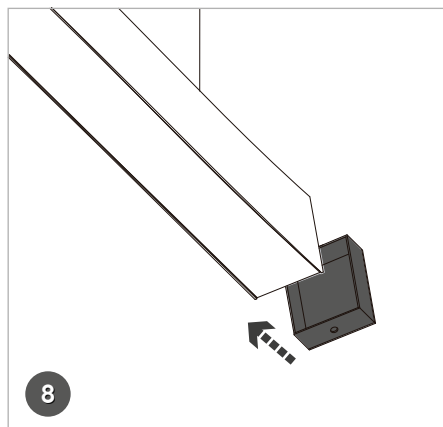
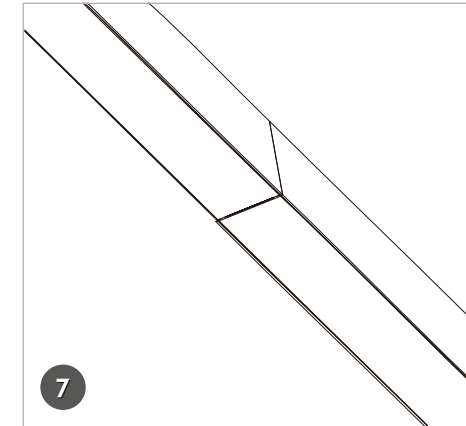
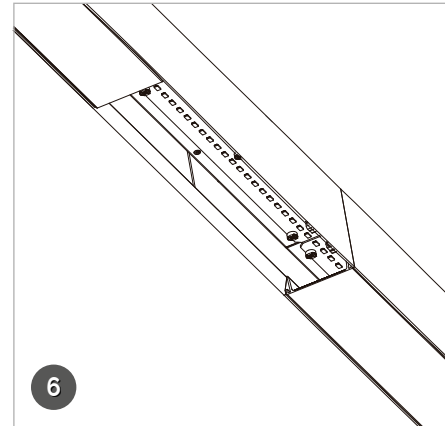
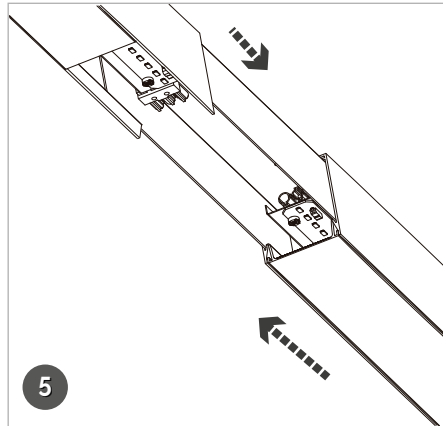
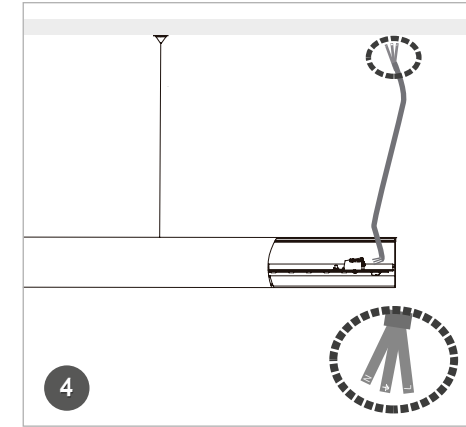
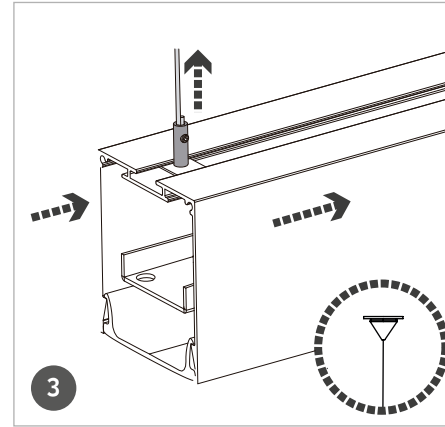
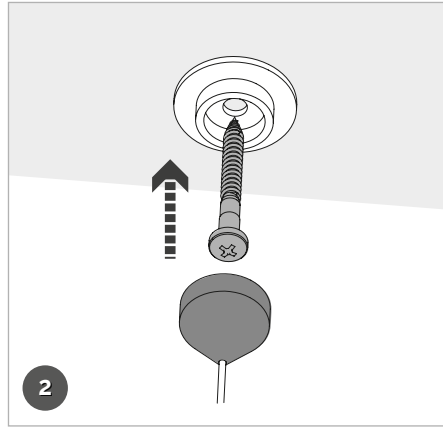

- | | | | |
|----------|--|--|---|
| 1 | <p>Desligar o disjuntor correspondente à linha em intervenção;</p> | <p>Turn off the circuit breaker corresponding to the intervention line</p> | <p>Désactivez le disjoncteur correspondant à l'intervention en ligne</p> |
| 2 | <p>Aparafusar a suspensão ao teto;
OPÇÃO I : KIT DE SUSPENSÃO</p> | <p>Screw the suspension to the ceiling;
OPTION I : SUSPENSION KIT</p> | <p>Visser la suspension au plafond;
OPTION I : KIT DE SUSPENSION</p> |
| 3 | <p>Ajustar a altura e posicionar o cabo, aparafusando os pernos superiores;</p> | <p>Adjust the height and position the handle by screwing in the upper bolts;</p> | <p>Réglez la hauteur et positionnez la poignée en vissant les boulons supérieurs ;</p> |
| 4 | <p>Eletrificar a luminária;
CONSULTAR ESQUEMA 1</p> | <p>Electrify the luminaire;
SEE SCHEME 1</p> | <p>Electrifier le luminaire ;
VOIR DIAGRAMME 1</p> |
| 5 | <p>Alinhar a luminária e proceder às ligações;</p> | <p>Align the luminaire and make the connections;</p> | <p>Aligner le luminaire et effectuer les connexions ;</p> |
| 6 | <p>Encaixe das luminárias;</p> | <p>Fitting the luminaires;</p> | <p>Montage des luminaires ;</p> |
| 7 | <p>Encaixe do difusor;</p> | <p>Diffuser fitting;</p> | <p>Raccord du diffuseur ;</p> |
| 8 | <p>Colocar o topo de acabamento no fim de linha;
SUSPENDER A LUMINÁRIA</p> | <p>Put the top trim at the end of the line;
SUSPEND THE LUMINAIRE</p> | <p>Placez la garniture supérieure à la fin de la ligne ;
SUSPENDRE LE LUMINAIRE</p> |
| 9 | <p>Ligar o disjuntor correspondente à linha em intervenção</p> | <p>Turn on the circuit breaker corresponding to the intervention line</p> | <p>Connectez le circuit correspondant disjoncteur à l'intervention de ligne</p> |

Nota
Note
Remarque

Este produto contém uma fonte de luz da classe energética A
This product contains an energy class A light source
Ce produit contient une source lumineuse de classe énergétique A

IMPORTANTE: Para mais informação sobre as diferentes arquitecturas, soluções e funcionalidades disponíveis, por favor contactar a Lightenjin.

São Rejeitadas todas as responsabilidades por defeito ou danos provocados por montagem incorrecta da luminária, incorrecta alimentação e agentes externos.

IMPORTANT: For more Information about different architectures, solutions and available functionalities, please contact Lightenjin

Are Rejected all liability for defects or damage caused by incorrect installation of the luminaire, Misfeeding and external agents.

IMPORTANT: Pour plus d'informations sur les différentes architectures de réseau, solutions et fonctionnalités disponibles, contactez Lightenjin.

Sont rejetées toute responsabilité pour les défauts ou les dommages causés par une mauvaise installation du luminaire, Mauvaise alimentation et les agents extérieurs.

Esquema 1 | Scheme 1 | Schéma 1

DALI/ 1-10 V

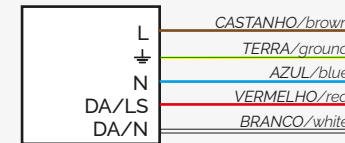

ON-OFF

