

MINI VITA

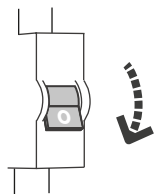

Instruções de montagem
Mounting instructions
Instructions de montage

1 OFF



LIGHTENJIN II - Indústria de Iluminação, Lda
Parque Empresarial do Casarão, Avenida das 2 Rodas,
Lote 36A. 3750-041 Aguada de Cima | Portugal
tel: +351 234 080 117 | fax: +351 234 640 064
geral@lightenjin.pt | www.lightenjin.pt

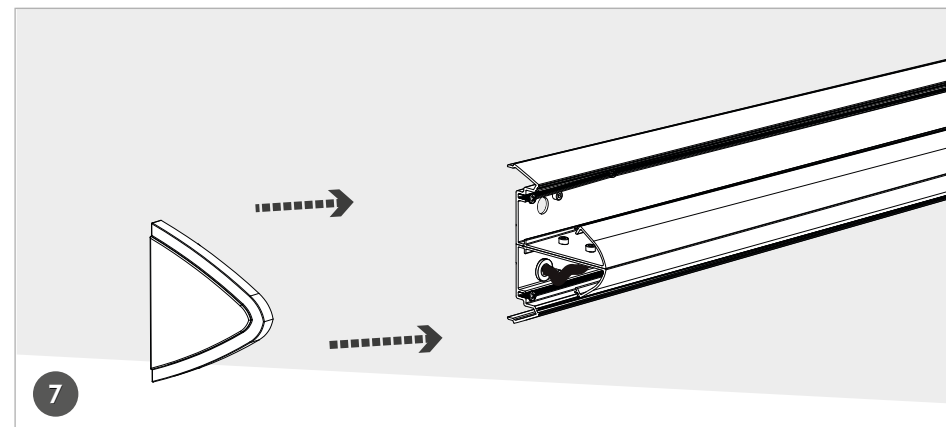
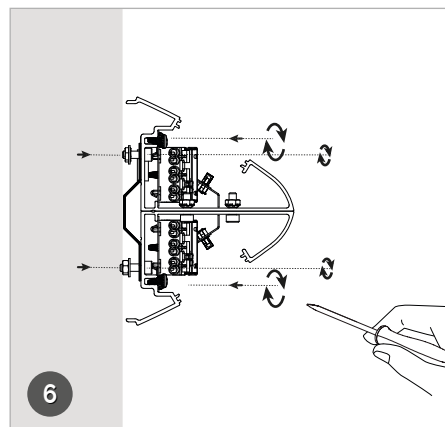
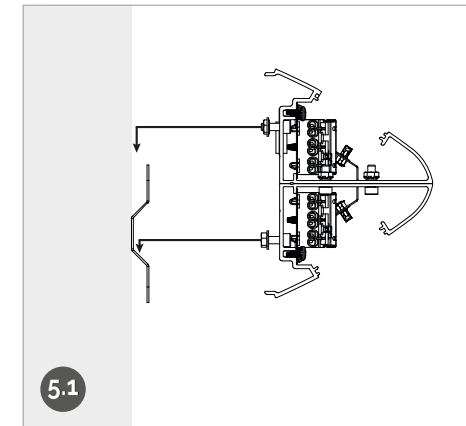
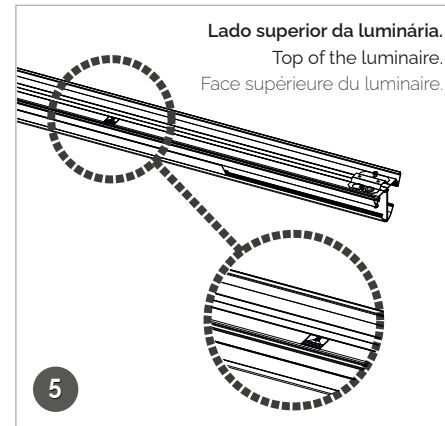
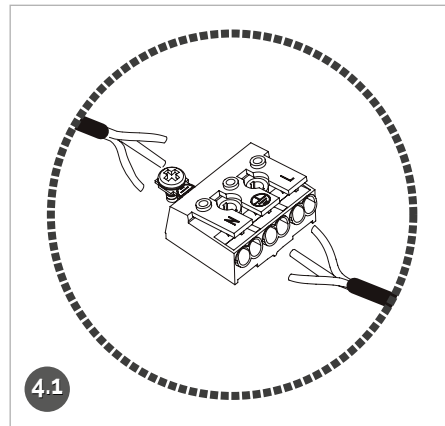
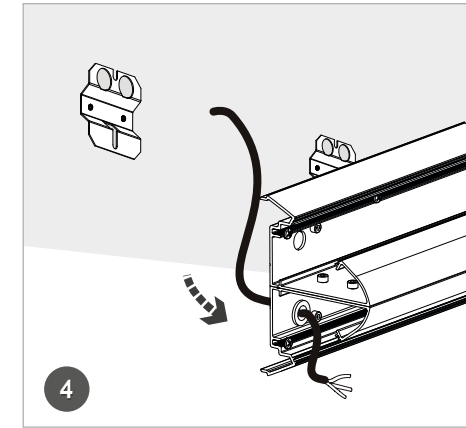
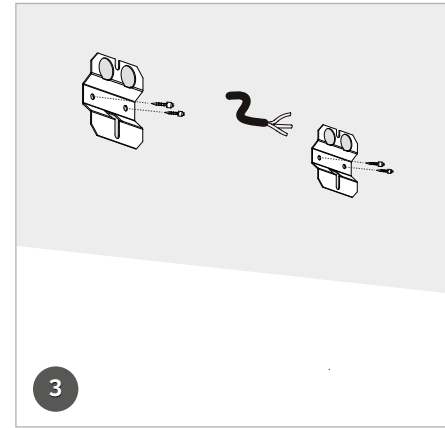
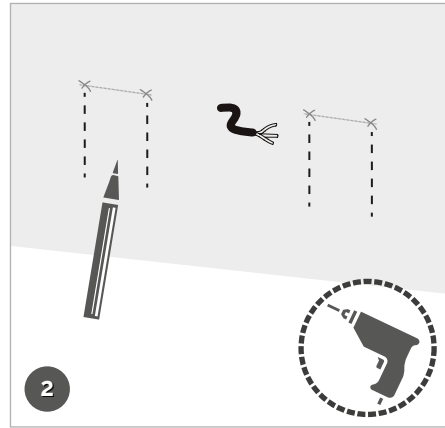

1

Desligar o disjuntor correspondente à linha em intervenção;

Turn off the circuit breaker corresponding to the intervention line

Désactivez le disjoncteur correspondant à l'intervention en ligne

2

Realizar as marcações e furos dos suportes na parede;

Mark and drill the brackets on the wall;

Marquez et percez les supports sur le mur ;

3

Fixar os suportes da luminária na parede;

Fix the luminaire brackets to the wall;

Fixer les supports du luminaire au mur ;

4

Eletrificar a luminária;
CONSULTAR ESQUEMA 1

Electrify the luminaire;
SEE SCHEME 1

Electrifier le luminaire ;
VOIR DIAGRAMME 1

5

Aplicar a luminária nos suportes, tendo em conta a orientação da instrução;

Apply the luminaire to the supports, following the instructions;

Appliquer le luminaire sur les supports en suivant les instructions ;

6

Aperatar os parafusos conforme a instrução;
UMA CHAVE SEGURA, OUTRA APERTA (INTERIOR DA LUMINÁRIA)

Align the luminaire and make the connections;
ONE KEY HOLDS, THE OTHER TIGHTENS (INSIDE THE LUMINAIRE)

Aligner le luminaire et effectuer les connexions ;
UNE CLÉ TIENT, L'AUTRE SERRE (À L'INTÉRIEUR DU LUMINAIRE)

7

Fechar a luminária;

Close the luminaire;

Fermer le luminaire ;

8

Ligar o disjuntor correspondente à linha em intervenção

Turn on the circuit breaker corresponding to the intervention line

Connectez le circuit correspondant disjoncteur à l'intervention de ligne

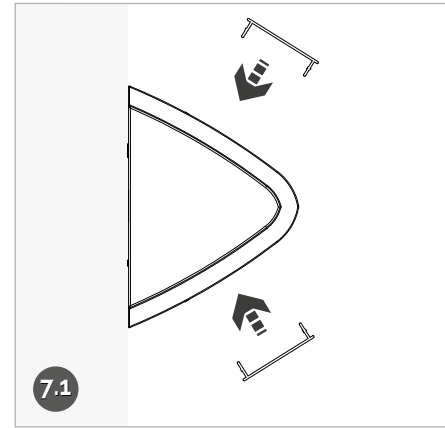

Esquema 1 | Scheme 1 | Schéma 1

DALI/ 1-10 V

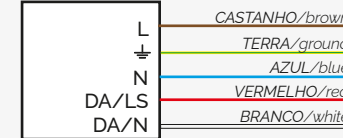

ON-OFF

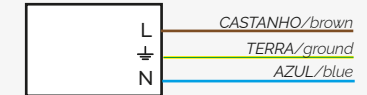

DALI/ 1-10 V + KIT

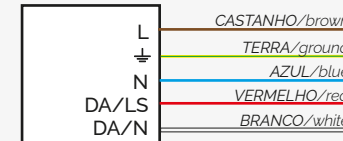

+

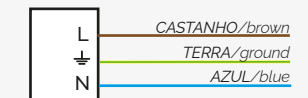

ON-OFF + KIT

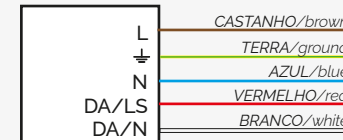

Nota
Note
Remarque

Este produto contém uma fonte de luz da classe energética A
This product contains an energy class A light source
Ce produit contient une source lumineuse de classe énergétique A

IMPORTANTE: Para mais informação sobre as diferentes arquiteturas, soluções e funcionalidades disponíveis, por favor contactar a Lightenjin.

São Rejeitadas todas as responsabilidades por defeito ou danos provocados por montagem incorrecta da luminária, incorrecta alimentação e agentes externos.

IMPORTANT: For more Information about different architectures, solutions and available functionalities, please contact Lightenjin

Are Rejected all liability for defects or damage caused by incorrect installation of the luminaire, Misfeeding and external agents.

IMPORTANT: Pour plus d'informations sur les différentes architectures de réseau, solutions et fonctionnalités disponibles, contactez Lightenjin.

Sont rejetées toute responsabilité pour les défauts ou les dommages causés par une mauvaise installation du luminaire, Mauvaise alimentation et les agents extérieurs.

