

NOXIS

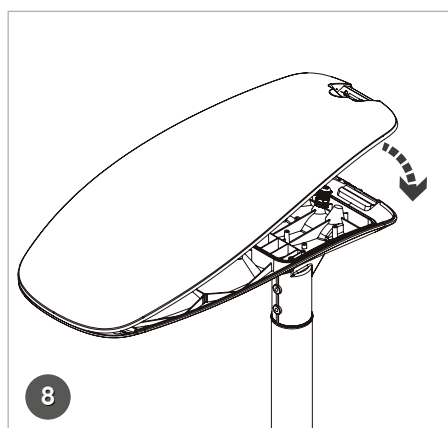

Instruções de montagem  
 Mounting instructions  
 Instructions de montage

1 OFF

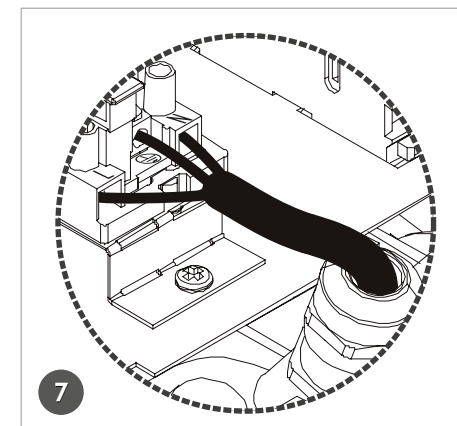
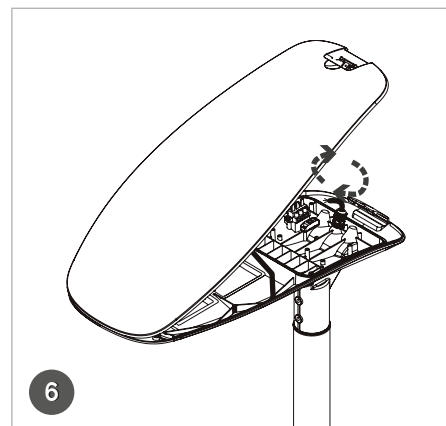
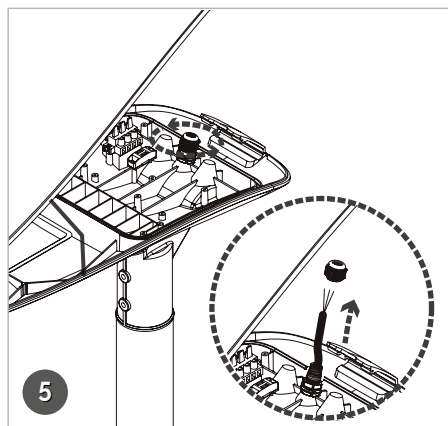
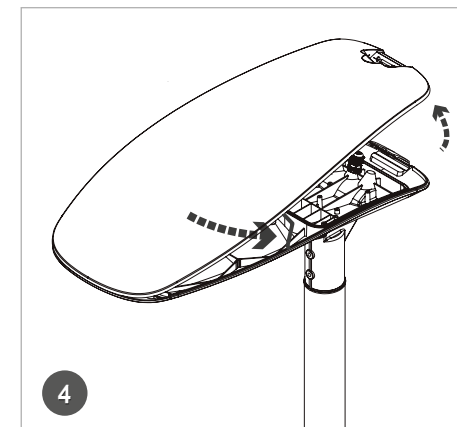
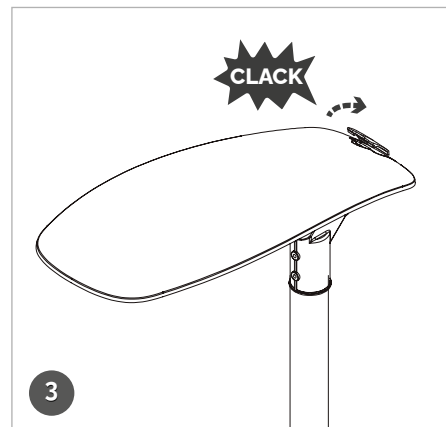
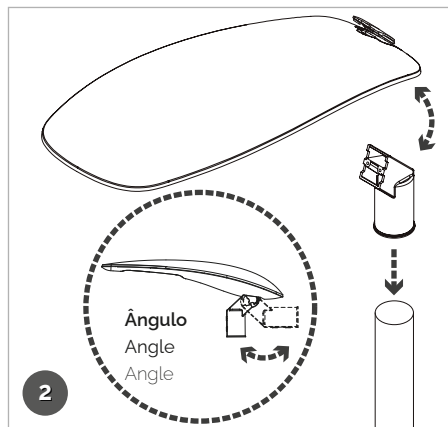
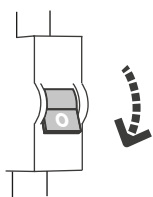

- |          |  |   |   |
|----------|--|---|---|
| <b>1</b> | <p><b>Desligar o disjuntor correspondente à linha em intervenção;</b><br/> <small>ACOMPANHAR ESTE MANUAL COM O FOLHETO DE NOTAS DO EQUIPAMENTO</small></p> | <p>Turn off the circuit breaker corresponding to the intervention line<br/> <small>ACCOMPANY THIS MANUAL WITH THE EQUIPMENT NOTES LEAFLET</small></p> | <p>Désactivez le disjoncteur correspondant à l'intervention en ligne<br/> <small>ACCOMPAGNER CE MANUEL DE LA NOTICE DE L'ÉQUIPEMENT</small></p> |
| <b>2</b> | <p><b>Unir o corpo da luminária ao braço, tendo em conta o ângulo;</b><br/> <b>Apertar o braço ao poste<sup>(*)</sup>;</b></p>                             | <p>Connect the body of the luminaire to the arm, taking the angle into account;<br/>             Fasten the arm to the pole<sup>(*)</sup>;</p>        | <p>Assembler le corps du luminaire au bras en tenant compte de l'angle ;<br/>             Fixer le bras au poteau<sup>(*)</sup> ;</p>           |
| <b>3</b> | <p><b>Abrir a tampa da luminária;</b></p>  | <p>Open the luminaire cover;</p>  | <p>Ouvrir le couvercle du luminaire ;</p>   |
| <b>4</b> | <p><b>Abrir o corpo da luminária, mantendo aberta com auxílio dos suportes;</b></p>  | <p>Open the body of the luminaire, holding it open with the help of the brackets;</p>   | <p>Ouvrir le corps du luminaire en le maintenant ouvert à l'aide des supports ;</p>   |
| <b>5</b> | <p><b>Aliviar o buçim e passar o cabo de alimentação;</b></p>  | <p>Loosen the cable gland and feed in the power cable;</p>  | <p>Alléger le presse-étoupe et introduire le câble d'alimentation ;</p>   |
| <b>6</b> | <p><b>Apertar o buçim;</b></p>   | <p>Tighten the cable gland;</p>   | <p>Serrer le presse-étoupe ;</p>  |
| <b>7</b> | <p><b>Eletrificar a luminária;</b><br/> <small>CONSULTAR ESQUEMA 1</small></p>   | <p>Electrify the luminaire;<br/> <small>SEE SCHEME 1</small></p>  | <p>Electrifier le luminaire ;<br/> <small>VOIR DIAGRAMME 1</small></p>  |
| <b>8</b> | <p><b>Fechar a luminária;</b></p>  | <p>Close the luminaire;</p>   | <p>Fermer le luminaire ;</p>  |
| <b>9</b> | <p><b>Ligar o disjuntor correspondente à linha em intervenção</b></p>  | <p>Turn on the circuit breaker corresponding to the intervention line</p>   | <p>Connectez le circuit correspondant disjoncteur à l'intervention de ligne</p>   |

Notas  
Notes  
Remarques

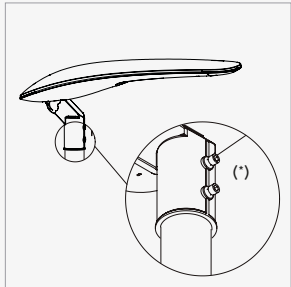

(\*)  
 Binário de aperto do parafuso de fixação de acordo com a norma EN 60598-2-3 (Máx. 8 N m)  
 Tightening torque of the fixing screw according to EN 60598-2-3 (Max. 8 N m)  
 Couple de serrage de la vis de fixation selon EN 60598-2-3 (Max. 8 N m)

Este manual de instruções deve ser acompanhado com o folheto de notas do equipamento.  
 This instruction manual must be accompanied by the equipment notes leaflet.  
 Ce manuel d'instructions doit être accompagné de la notice de l'appareil.

Este produto contém uma fonte de luz da classe energética A  
 This product contains an energy class A light source  
 Ce produit contient une source lumineuse de classe énergétique A

Esquema 1 | Scheme 1 | Schéma 1

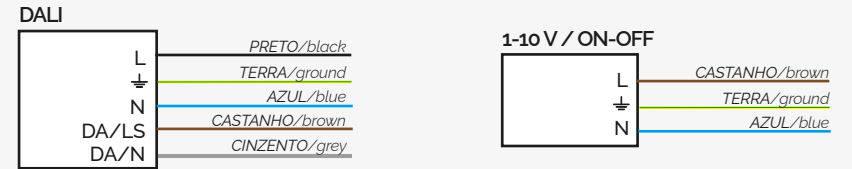

**IMPORTANTE:** Para mais informação sobre as diferentes arquiteturas, soluções e funcionalidades disponíveis, por favor contactar a Lightenjin.

São Rejeitadas todas as responsabilidades por defeito ou danos provocados por montagem incorrecta da luminária, incorrecta alimentação e agentes externos.

**IMPORTANT:** For more information about different architectures, solutions and available functionalities, please contact Lightenjin

Are Rejected all liability for defects or damage caused by incorrect installation of the luminaire, Misfeeding and external agents.

**IMPORTANT:** Pour plus d'informations sur les différentes architectures de réseau, solutions et fonctionnalités disponibles, contactez Lightenjin.

Sont rejetées toute responsabilité pour les défauts ou les dommages causés par une mauvaise installation du luminaire, Mauvaise alimentation et les agents extérieures.

