

PURUS

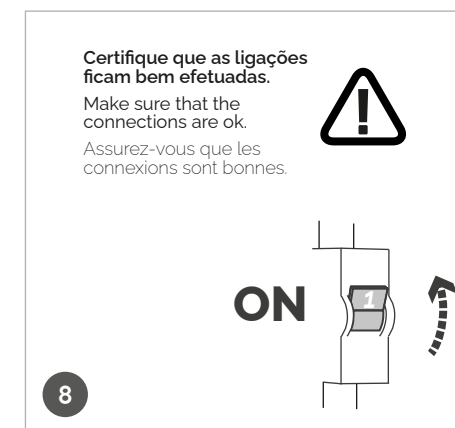

Instruções de montagem  
Mounting instructions  
Instructions de montage

1 OFF

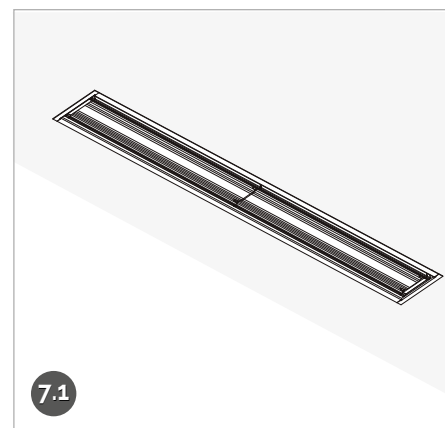
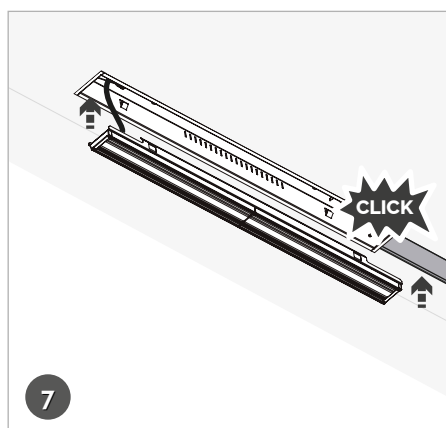
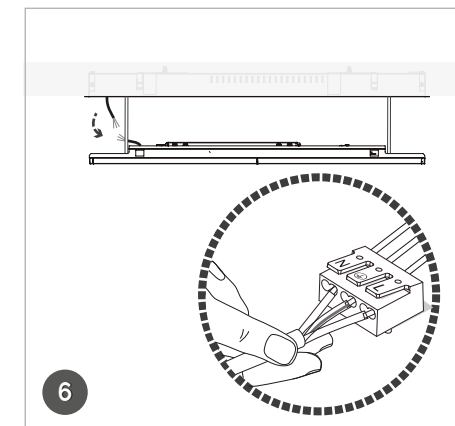
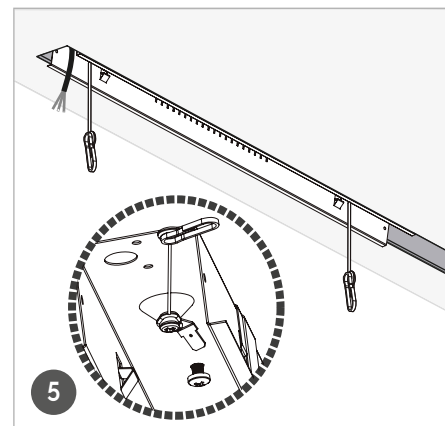
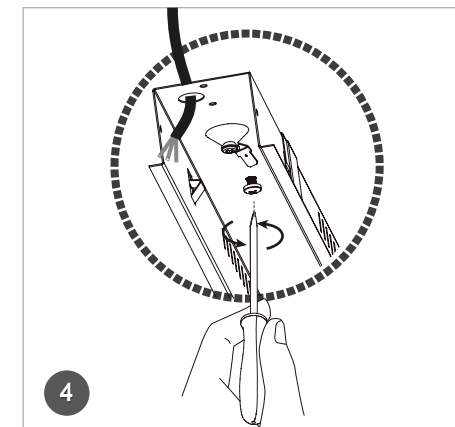
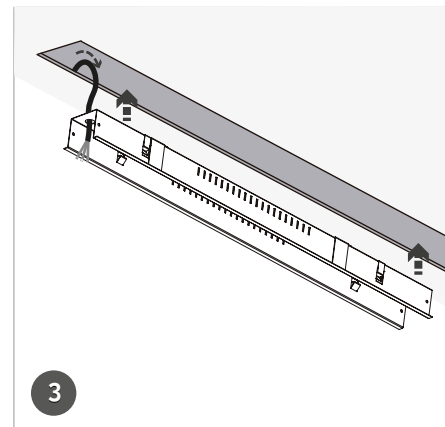
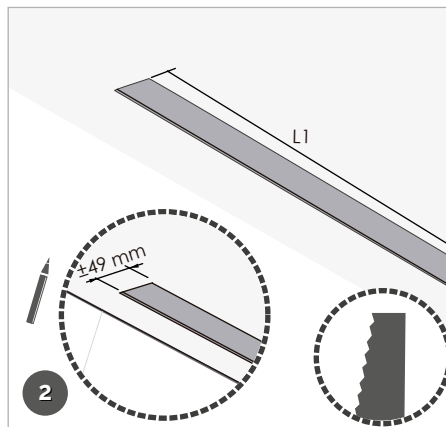
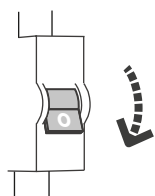

- 1** Desligar o disjuntor correspondente à linha em intervenção;

Turn off the circuit breaker corresponding to the intervention line

Désactivez le disjoncteur correspondant à l'intervention en ligne
- 2** Realizar as marcações, e abrir furo no teto;

CONSULTAR TABELA 1

Make the markings and drill a hole in the ceiling;

SEE TABLE 1

Faites les marques et percez un trou dans le plafond ;

VOIR TABLEAU 1
- 3** Passar o cabo de alimentação pelo negativo e aparafusar o negativo ao teto;

Pass the power cable through the negative and screw the negative to the ceiling;

Passez le câble d'alimentation dans le négatif et vissez le négatif au plafond ;
- 4** Aparafusar os niveladores;

Screw on the levelers;

Visser les niveleurs ;
- 5** Fixar os cabos de aço no negativo e na luminária;

Attach the steel cables to the negative and the luminaire;

Attachez les câbles d'acier au négatif et au luminaire ;
- 6** Eletrificar a luminária;

CONSULTAR ESQUEMA 1

Electrify the luminaire;

SEE SCHEME 1

Electrifier le luminaire ;

VOIR DIAGRAMME 1
- 7** Aplicar a luminária;

(\*) GARANTIR TANGÊNCIA DA LUMINÁRIA NO TETO

Apply the luminaire;

(\*) ENSURE TANGENCY OF THE LUMINAIRE TO THE CEILING

Appliquer le luminaire ;

(\*) ASSURER LA TANGENCE DU LUMINAIRE PAR RAPPORT AU PLAFOND
- 8** Ligar o disjuntor correspondente à linha em intervenção

Turn on the circuit breaker corresponding to the intervention line

Connectez le circuit correspondant disjoncteur à l'intervention de ligne

Tabela 1 | Table 1 | Tableau 1

L1 (mm)	FURO NO TETO (mm) HOLE IN THE CEILING   TROU DANS LE TOIT
576	49x579
1140	49x1143
1704	49x1707

MODELO INDIVIDUAL  
INDIVIDUAL MODEL | MODÈLE INDIVIDUEL

DETALHE TÉCNICO  
TECHNICAL DETAILS | DÉTAILS TECHNIQUES

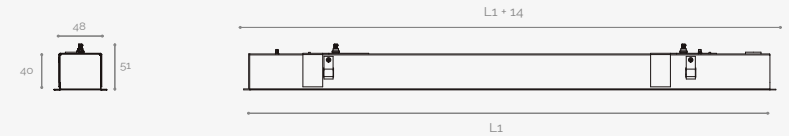

Esquema 1 | Scheme 1 | Schéma 1

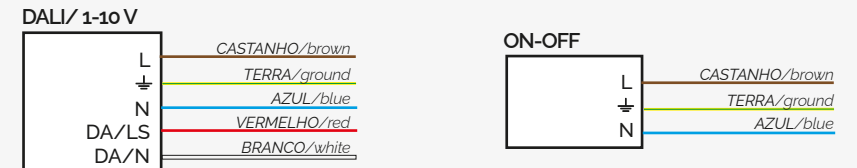

Nota  
Note  
Remarque

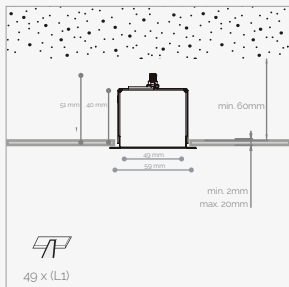

Este produto contém uma fonte de luz da classe energética A  
This product contains an energy class A light source  
Ce produit contient une source lumineuse de classe énergétique A

**IMPORTANTE:** Para mais informação sobre as diferentes arquiteturas, soluções e funcionalidades disponíveis, por favor contactar a Lightenjin.

São Rejeitadas todas as responsabilidades por defeito ou danos provocados por montagem incorrecta da luminária, incorrecta alimentação e agentes externos.

**IMPORTANT:** For more information about different architectures, solutions and available functionalities, please contact Lightenjin

Are Rejected all liability for defects or damage caused by incorrect installation of the luminaire, Misfeeding and external agents.

**IMPORTANT:** Pour plus d'informations sur les différentes architectures de réseau, solutions et fonctionnalités disponibles, contactez Lightenjin.

Sont rejetées toute responsabilité pour les défauts ou les dommages causés par une mauvaise installation du luminaire, Mauvaise alimentation et les agents extérieurs.

