

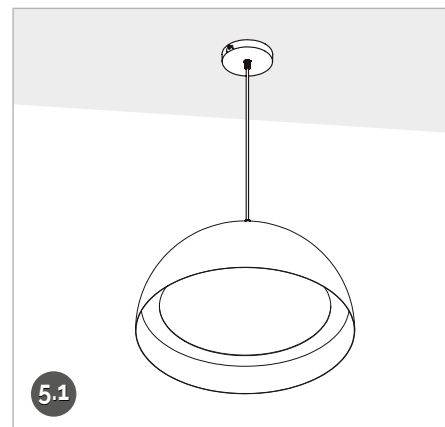

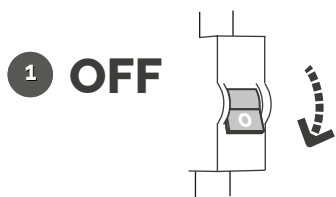

RUSTICUS

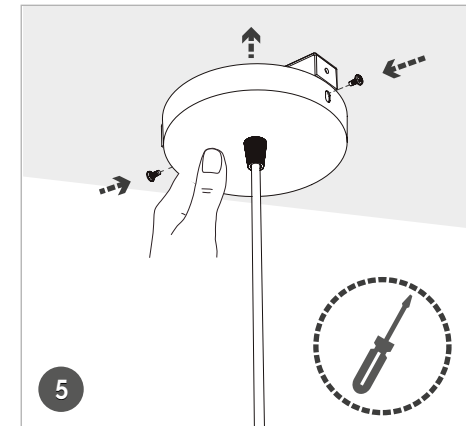
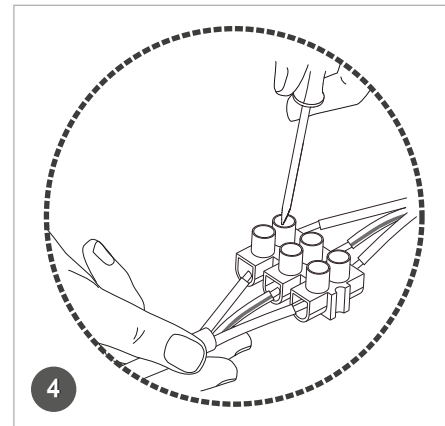
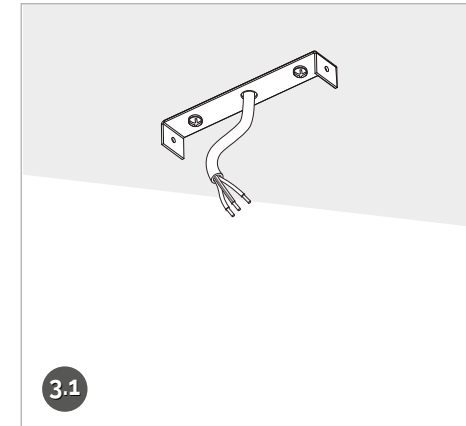
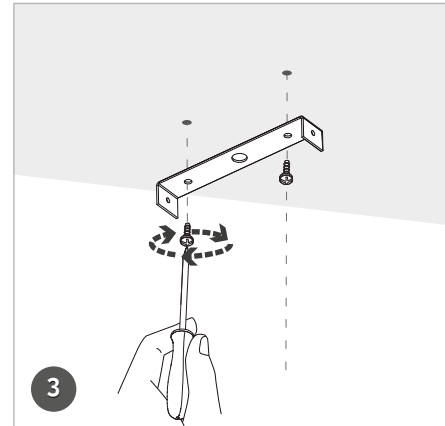
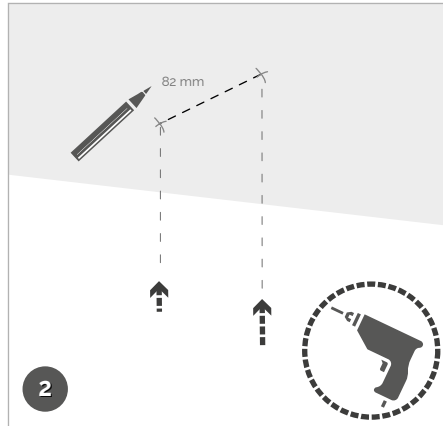

Instruções de montagem
 Mounting instructions
 Instructions de montage



- 1**  **Desligar o disjuntor correspondente à linha em intervenção;**
Turn off the circuit breaker corresponding to the intervention line
Désactivez le disjoncteur correspondant à l'intervention en ligne
- 2** **Realizar as marcações e proceder à furação;**
DISTÂNCIA ENTRE FURÓS: 82mm
Make the markings and drill the holes;
DISTANCE BETWEEN HOLES: 82mm
Faites les marques et percez les trous;
DISTANCE ENTRE LES TROUS : 82mm
- 3**  **Aplicar o suporte de fixação da base de topo no teto;**
PASSAR O CABO DE ALIMENTAÇÃO
Apply the top base fixing bracket to the ceiling;
PASS THE POWER CABLE
Appliquer le support de fixation de la base supérieure au plafond;
ACHEMINER LE CÂBLE D'ALIMENTATION
- 4**  **Eletrificar a luminária;**
CONSULTAR ESQUEMA 1
Electrify the luminaire;
SEE SCHEME 1
Electrifier le luminaire ;
VOIR DIAGRAMME 1
- 5** **Fixar a base de topo;**
SUSPENDER A LUMINÁRIA
Attach the top base;
SUSPEND THE LUMINAIRE
Fixer la base supérieure ;
SUSPENDRE LE LUMINAIRE
- 6**  **Ligar o disjuntor correspondente à linha em intervenção**
Turn on the circuit breaker corresponding to the intervention line
Connectez le circuit correspondant disjoncteur à l'intervention de ligne

Nota
Note
Remarque

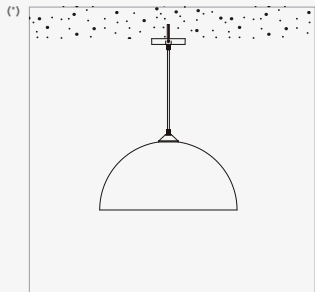

Este produto contém uma fonte de luz da classe energética A
This product contains an energy class A light source
Ce produit contient une source lumineuse de classe énergétique A

IMPORTANTE: Para mais informação sobre as diferentes arquiteturas, soluções e funcionalidades disponíveis, por favor contactar a Lightenjin.

São Rejeitadas todas as responsabilidades por defeito ou danos provocados por montagem incorrecta da luminária, incorrecta alimentação e agentes externos.

IMPORTANT: For more information about different architectures, solutions and available functionalities, please contact Lightenjin

Are Rejected all liability for defects or damage caused by incorrect installation of the luminaire, Misfeeding and external agents.

IMPORTANT: Pour plus d'informations sur les différentes architectures de réseau, solutions et fonctionnalités disponibles, contactez Lightenjin.

Sont rejetées toute responsabilité pour les défauts ou les dommages causés par une mauvaise installation du luminaire, Mauvaise alimentation et les agents extérieurs.

Esquema 1 | Scheme 1 | Schéma 1

