

TURNLINNE

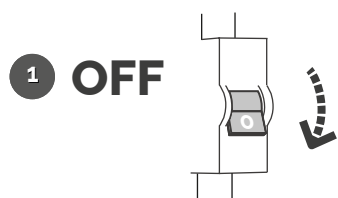

Instruções de montagem
Mounting instructions
Instructions de montage

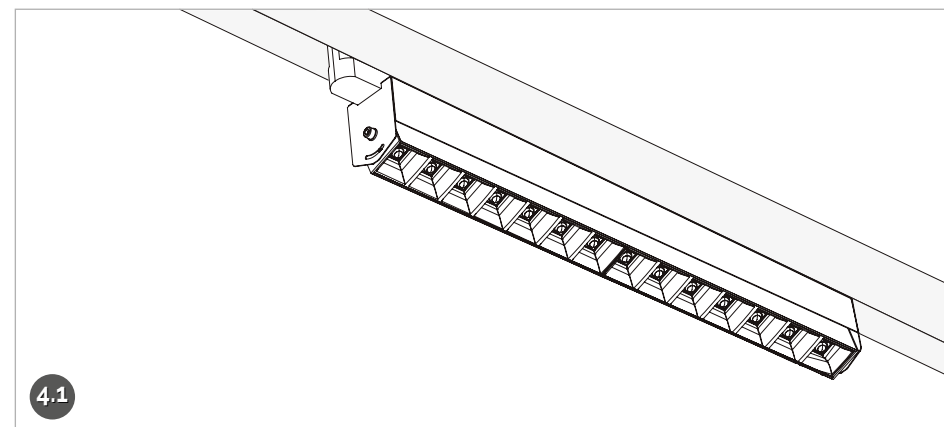
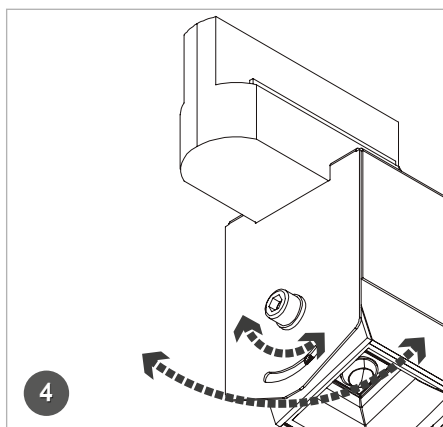
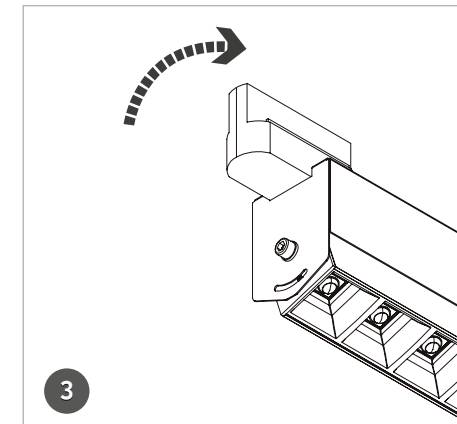
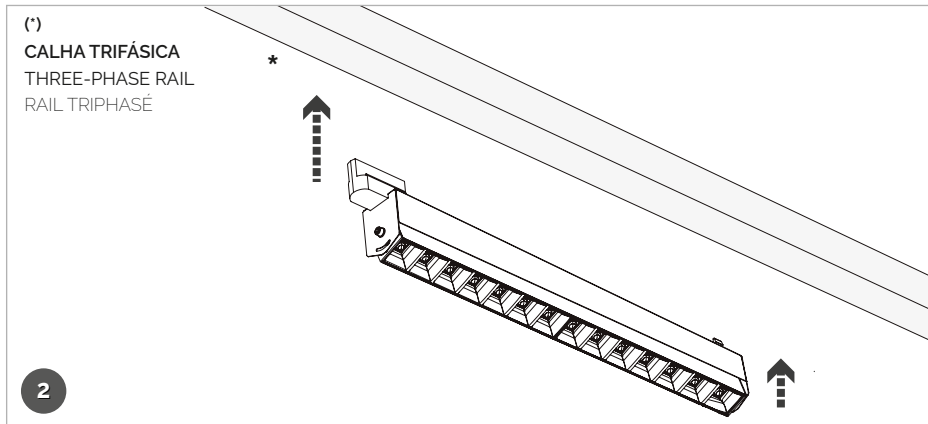

- | | | | |
|----------|--|--|---|
| 1 | <p>Desligar o disjuntor correspondente à linha em intervenção;</p> | <p>Turn off the circuit breaker corresponding to the intervention line</p> | <p>Désactivez le disjoncteur correspondant à l'intervention en ligne</p> |
| 2 | <p>Alinhar a driver da luminária à calha trifásica;</p> | <p>Align the luminaire driver with the three-phase rail;</p> | <p>Aligner le driver du luminaire avec le rail triphasé ;</p> |
| 3 | <p>Rodar o clip da driver para fixar na calha;
 <small>ESCOLHER A FASE PRETENDIDA</small></p> | <p>Turn the driver clip to secure it to the rail;
 <small>CHOOSE THE DESIRED PHASE</small></p> | <p>Tournez le clip du conducteur pour le fixer au rail ;
 <small>CHOISIR LA PHASE SOUHAITÉE</small></p> |
| 4 | <p>Ajustar a posição com o parafuso;</p> | <p>Adjust the position with the screw;</p> | <p>Ajuster la position à l'aide de la vis ;</p> |
| 5 | <p>Ligar o disjuntor correspondente à linha em intervenção</p> | <p>Turn on the circuit breaker corresponding to the intervention line</p> | <p>Connectez le circuit correspondant disjoncteur à l'intervention de ligne</p> |

Nota
 Note
 Remarque

Este produto contém uma fonte de luz da classe energética A
 This product contains an energy class A light source
 Ce produit contient une source lumineuse de classe énergétique A

IMPORTANTE: Para mais informação sobre as diferentes arquiteturas, soluções e funcionalidades disponíveis, por favor contactar a Lightenjin.
 São Rejeitadas todas as responsabilidades por defeito ou danos provocados por montagem incorrecta da luminária, incorrecta alimentação e agentes externos.

IMPORTANT. For more Information about different architectures, solutions and available functionalities, please contact Lightenjin
 Are Rejected all liability for defects or damage caused by incorrect installation of the Luminaire, Misfeeding and external agents.

IMPORTANT. Pour plus d'informations sur les différentes architectures de réseau, solutions et fonctionnalités disponibles, contactez Lightenjin.
 Sont rejetées toute responsabilité pour les défauts ou les dommages causés par une mauvaise installation du luminaire, Mauvaise alimentation et les agents extérieurs.

Esquema 1 | Scheme 1 | Schéma 1

