

UNNO PLUS

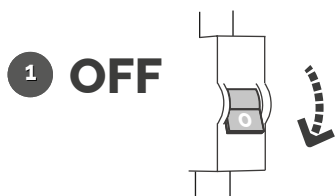

Instruções de montagem
Mounting instructions
Instructions de montage

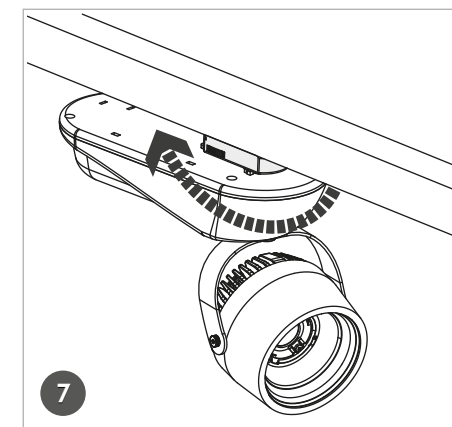
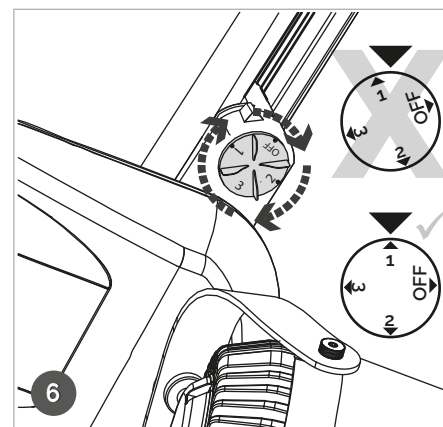
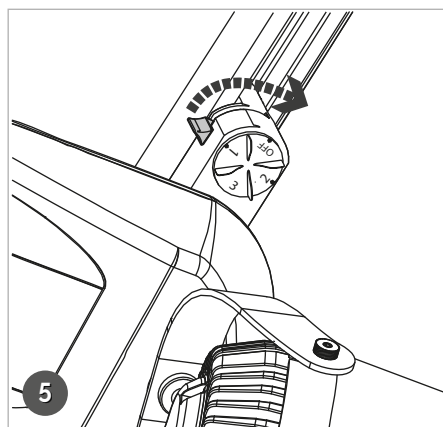
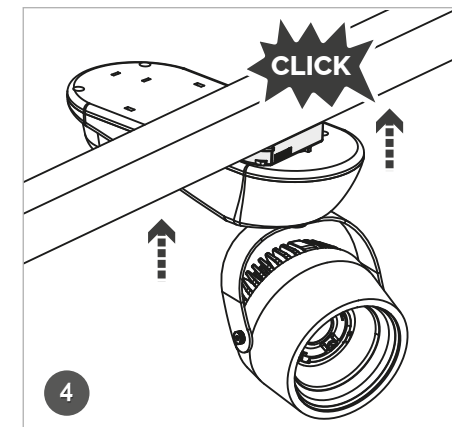
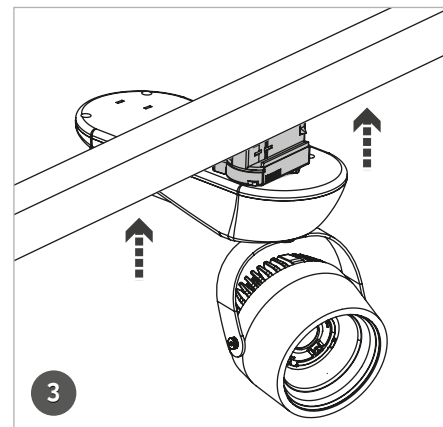
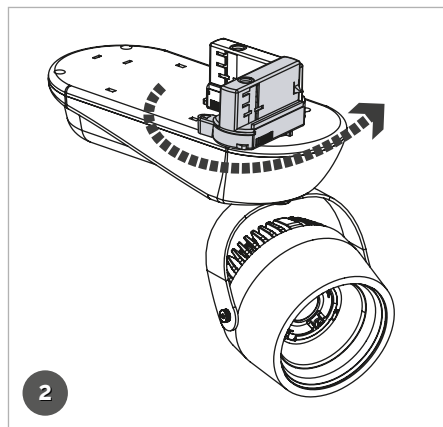

LIGHTENJIN II - Indústria de Iluminação, Lda
Parque Empresarial do Casarão, Avenida das 2 Rodas,
Lote 36A. 3750-041 Aguada de Cima | Portugal
tel: +351 234 080 117 | fax: +351 234 640 064
geral@lightenjin.pt | www.lightenjin.pt

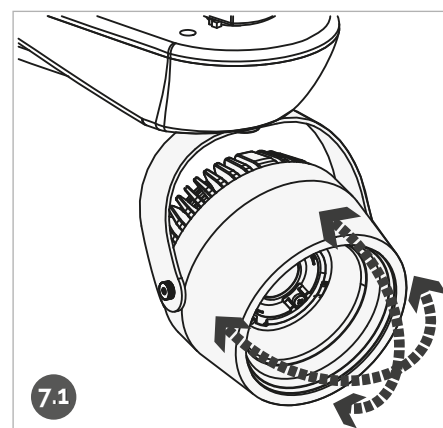

Certifique que as ligações
ficam bem efetuadas.
Make sure that the
connections are ok.
Assurez-vous que les
connexions sont bonnes.

- | | | | |
|----------|---|--|---|
| 1 | Desligar o disjuntor correspondente à linha em intervenção; | Turn off the circuit breaker corresponding to the intervention line | Désactivez le disjoncteur correspondant à l'intervention en ligne |
| 2 | Posicionar o adaptador; | Position the adapter; | Positionner l'adaptateur ; |
| 3 | Posicionar o adaptador na calha, com atenção para a ligação terra;
<small>CONSULTAR ESQUEMA 1</small> | Position the adapter on the rail, paying attention to the earth connection;
<small>SEE SCHEME 1</small> | Positionner l'adaptateur sur le rail en faisant attention à la mise à la terre ;
<small>VOIR DIAGRAMME 1</small> |
| 4 | Precionar o projetor contra a calha até bloquear; | Press the projector against the rail until it locks; | Pressez le projecteur contre le rail jusqu'à ce qu'il se verrouille ; |
| 5 | Pressionar a patilha 90°; | Press the tab 90°; | Appuyez sur la languette à 90° ; |
| 6 | Selecionar a fase; | Select the phase; | Sélectionnez la phase ; |
| 7 | Ajustar o posicionamento da luminária; | Adjust the positioning of the luminaire; | Ajuster le positionnement du luminaire ; |
| 8 | Ligar o disjuntor correspondente à linha em intervenção | Turn on the circuit breaker corresponding to the intervention line | Connectez le circuit correspondant disjoncteur à l'intervention de ligne |

Nota
Note
Remarque

Este produto contém uma fonte de luz da classe energética A
This product contains an energy class A light source
Ce produit contient une source lumineuse de classe énergétique A

IMPORTANTE: Para mais informação sobre as diferentes arquiteturas, soluções e funcionalidades disponíveis, por favor contactar a Lightenjin.

São Rejeitadas todas as responsabilidades por defeito ou danos provocados por montagem incorrecta da luminária, incorrecta alimentação e agentes externos.

IMPORTANT: For more Information about different architectures, solutions and available functionalities, please contact Lightenjin

Are Rejected all liability for defects or damage caused by incorrect installation of the luminaire, Misfeeding and external agents.

IMPORTANT: Pour plus d'informations sur les différentes architectures de réseau, solutions et fonctionnalités disponibles, contactez Lightenjin.

Sont rejetées toute responsabilité pour les défauts ou les dommages causés par une mauvaise installation du luminaire, Mauvaise alimentation et les agents extérieurs.

Esquema 1 | Scheme 1 | Schéma 1

